

Set-Up and Use of Bergquist 5-Wire Controller

FEATURES

- Jumper-selectable RS-232, PS/2 and USB communications options
- 5-Wire resistive analog touch screen interface
- Jumper selectable regulated, unregulated or “power-from-port” power options
- 10-bit resolution

PRODUCT DESCRIPTION

Bergquist's 5-Wire touch screen controller board sets a new standard in resistive analog touch screen controller technology. The 5-Wire touch screen controller utilizes leading-edge decoding techniques to quickly and accurately decode touch points in 5-Wire resistive analog touch screen applications. For greater design flexibility, the 5-Wire controller board may be user-configured for RS-232, PS/2 or USB communication with regulated, un-regulated, or “power-from-port” power.

Bergquist takes the guesswork out of touch screen system design. Bergquist's 5-Wire controllers are the perfect match to the superior optics, flexibility and durable performance of Bergquist's 5-Wire resistive analog touch screens. The result is a truly integrated system of touch screen hardware and software solutions tailor made for your application.

BEFORE YOU BEGIN

This manual assumes 5-Wire controller boards are to be used in combination with Bergquist device drivers. It is further assumed the user has taken all necessary steps to ensure that the application of Bergquist products meet safety and performance requirements including any laws, regulations, codes and standards associated with user application.

The 5-Wire touch screen controller and software described within this document are assumed to be used with Bergquist 5-Wire resistive analog touch screen products.

Important Notes

- Use jumper settings and connection diagrams for identifying the correct board configuration for your application.
- The board revision and firmware release can be found directly on your Bergquist touch screen controller board. Please contact The Bergquist Company if you have any questions regarding your hardware revision.

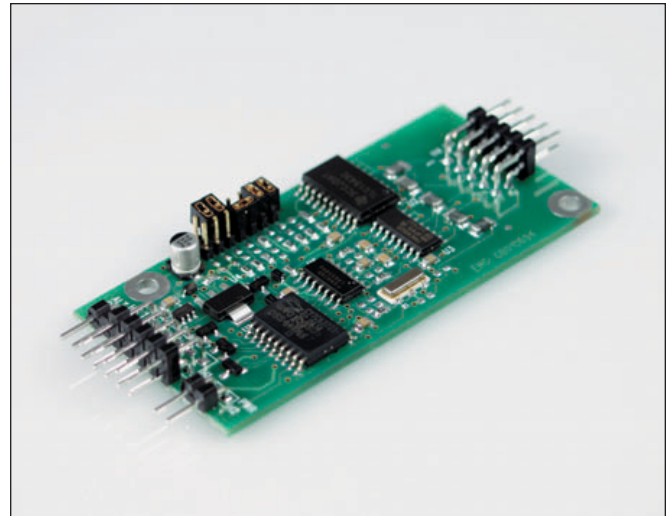

WARNING!

Although The Bergquist Company has taken steps to protect your touch screen controller from transient voltage, it is important to verify that all connections to the controller are correct and take adequate static precautions when connecting the Bergquist controller in your application. Failure to follow this procedure may result in damage to your controller and/or communication port.

CONTENTS

Product Features and Description	1
Mechanical Specifications	2
Electrical Specifications	2
Quick-View Assembly Diagram	3
Assembly Instructions	4
Connection Hardware and Cable Assemblies	6
Communication Format	7

MECHANICAL SPECIFICATIONS

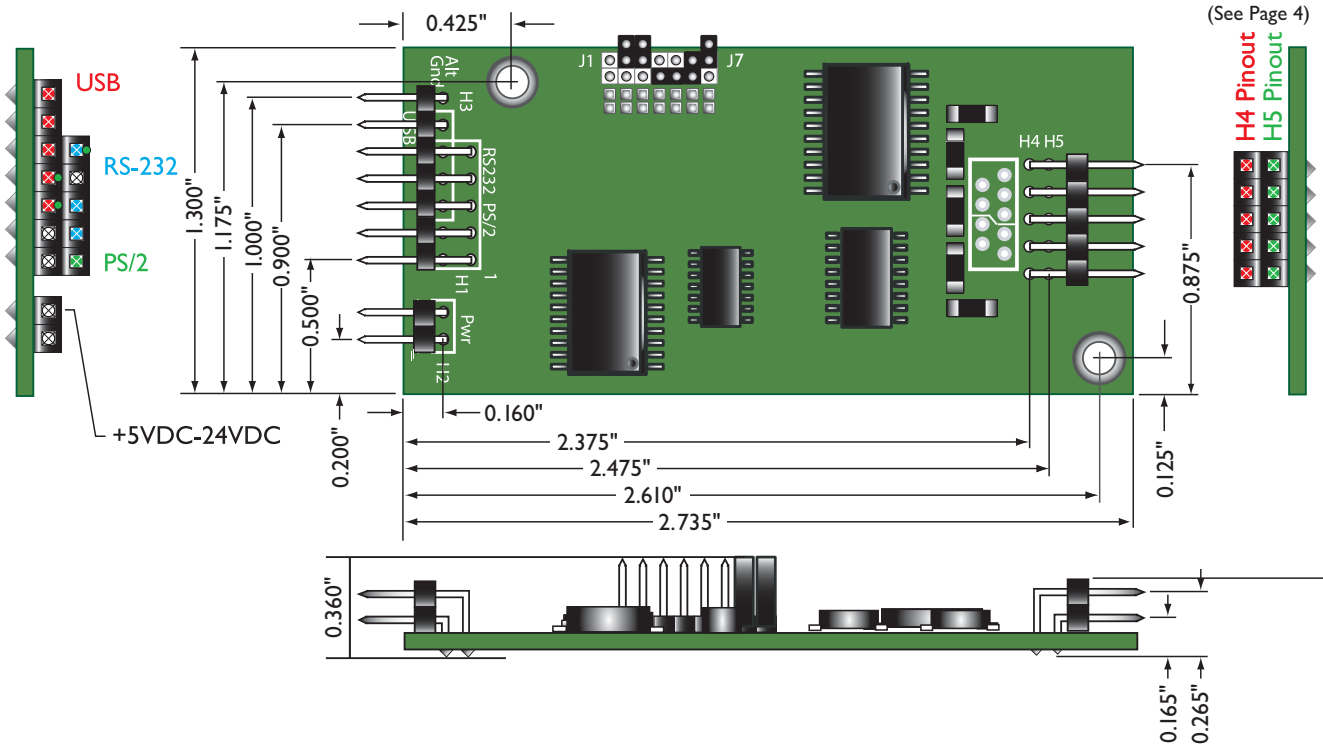

ELECTRICAL SPECIFICATIONS

Available Drivers

- DOS, Windows: 9x, NT, 2000, ME, XP, XPpro, CE, Linux, WindRiver and QNX. Contact your Bergquist representative if you require a customized driver for your application.

Communications

- USB, Universal Serial Bus
- RS232 - 9600 baud rate
- PS/2, Personal System / 2

Touch Screen Interface

- Resistive Analog 5-Wire

Resolution

- 10 bit (1,096 x 1,096) 1,048,578. points in the field

Transmission Speed

~40 - 100 dynamic points / second

Clock Frequency

- 6.0 MHz

Environmental

- Operating temperature 0° C to 70° C
- Storage temperature -40° C to 85° C

Static Protection

- 24 kV

Calibration

- Software (driver) calibration for all PC and Mac configurations.
- Bergquist drivers include proprietary 4-point and 20-point calibration to compensate for non-linear or non-square linearization patterns.
- 3 and 7point standard touch screen calibration algorithms.

Power

Power-from-Port (PS/2 and USB Only): 5 VDC +/- 10%

External Regulated Power: 5 VDC +/- 10%

External Unregulated Power: 7.5 VDC < 25 VDC

NOTE: Power options are jumper configurable. See "Set Power Jumpers" diagrams on page 4.

BERGQUIST 5-WIRE QUICK-VIEW ASSEMBLY DIAGRAM

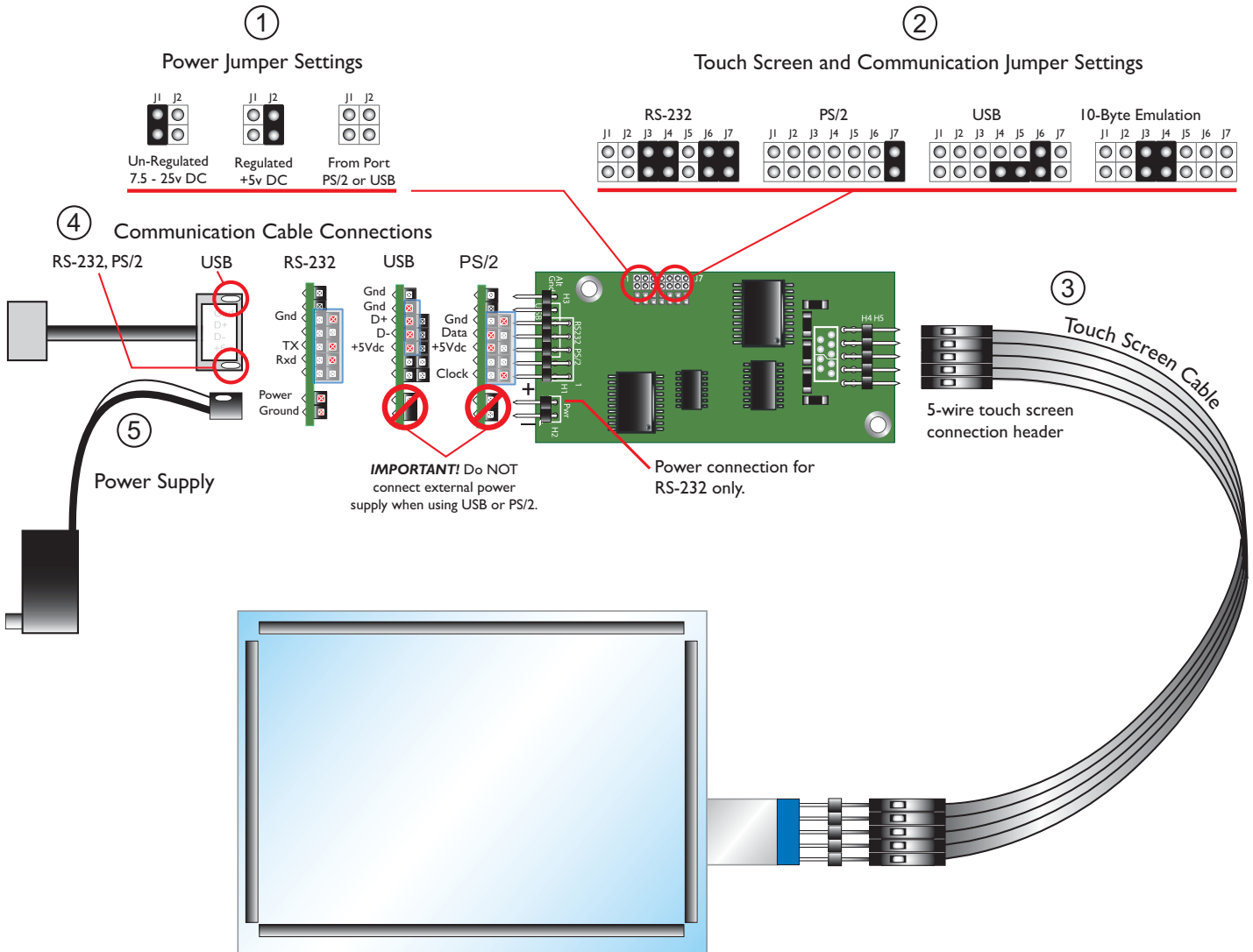

Assembly Instructions

1. Set power jumpers. (**NOTE:** Typically, a 9VDC power supply is included with a 5-Wire developers kit. Check power supply before setting power jumpers.)
2. Set touch screen communication jumpers.
3. Connect touch screen cable.
4. Connect communications cable.
5. Connect power (if necessary). (**IMPORTANT NOTE:** Do NOT connect external power supply when using USB or PS/2.)
6. Turn on computer.
7. Install 5-Wire drivers.
8. Follow the on-screen instructions.

ASSEMBLY INSTRUCTIONS

1. Set Power Jumpers

Configure your power jumper for regulated or un-regulated power. Use power-from-port settings for USB and PS/2 applications. **IMPORTANT! INCORRECT JUMPER SETTINGS WILL DAMAGE YOUR 5-WIRE BOARD.**

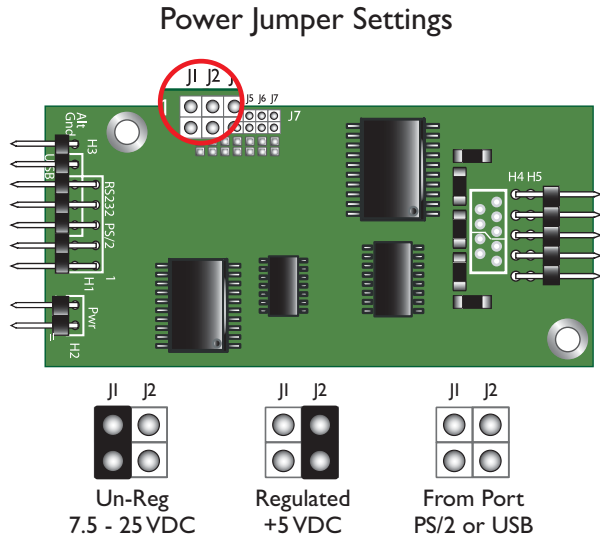

NOTE: 5-Wire controller boards are delivered pre-set for USB applications with additional jumpers supplied.

2. Set Communication Jumpers

Jumper settings must be set for communication options as well as power. Use power-from-port settings for USB and PS/2 applications. **IMPORTANT! INCORRECT JUMPER SETTINGS WILL DAMAGE YOUR 5-WIRE BOARD.**

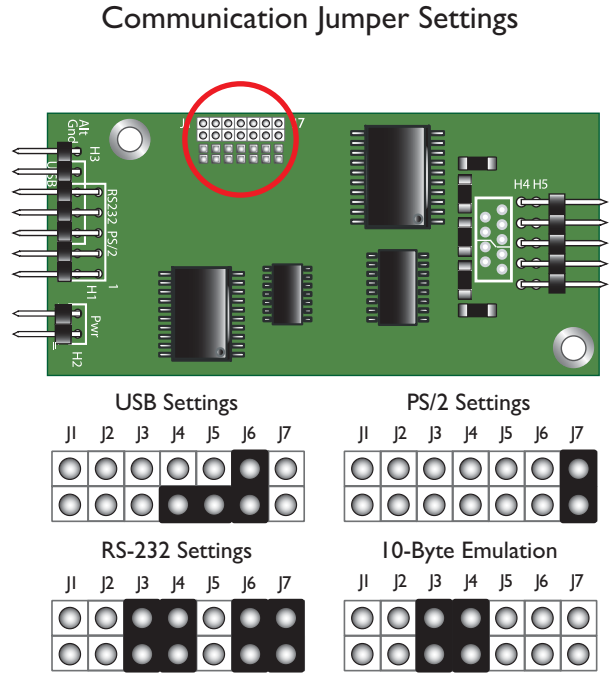

3. Connect Touch Screen Cable

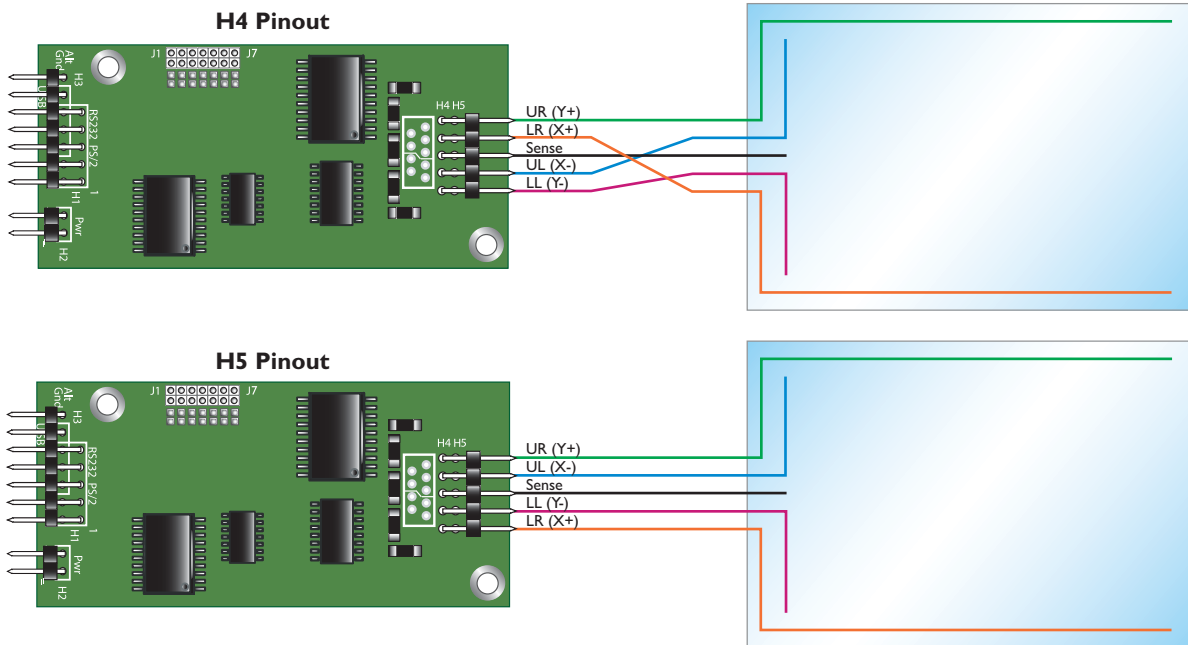

4. Connect Communication Cable

USB Connection

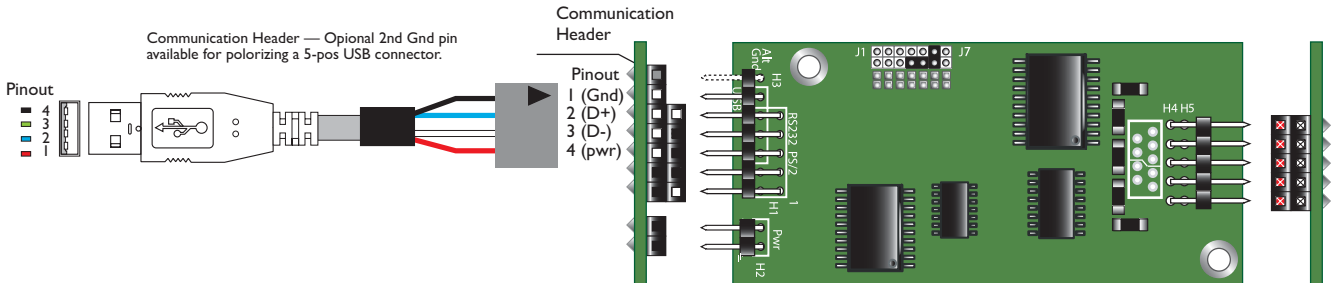

NOTE: Make sure that you have set the jumpers for power-from-port before connecting to the USB port.

RS-232 Connection

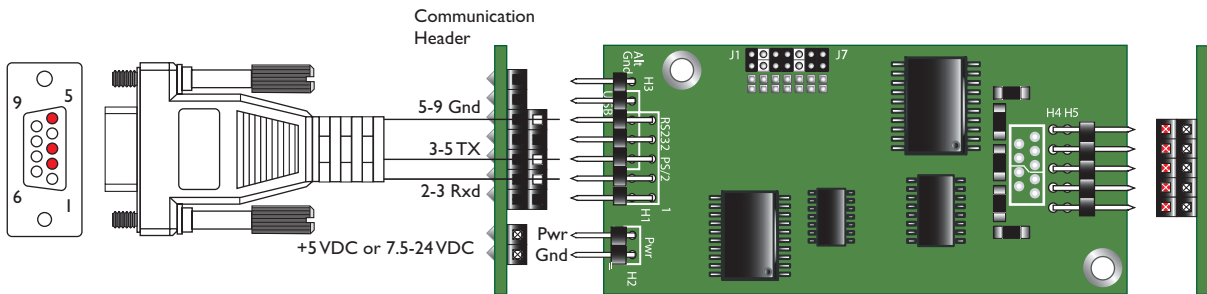

IMPORTANT! Make sure the power jumpers are set properly for 5 VDC regulated or 7.5 - 24 VDC unregulated power before supplying power to the board.

NOTE: A standard IDC RS-232 (DB-9) to 10-position dual row socket jumper cable assembly may be used.
Pin out: 1-1, 2-3, 3-5, 4-7, 5-9, 6-2, 7-4, 8-6, 9-8, NC-10

PS/2 Connection

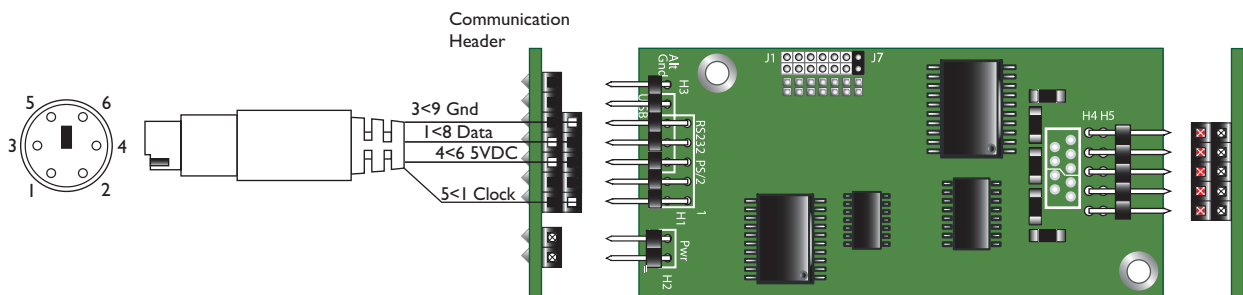

IMPORTANT! Make sure the power jumpers are set for Power from Port.
WARNING! DO NOT CONNECT POWER TO THE POWER HEADERS!!

NOTE: Make sure that you have set the jumpers for power-from-port before connecting to the PS/2 port.

5. Connect Power (if necessary)

IMPORTANT! Do NOT connect external power supply in USB or RS-232 applications.

7. Install 5-Wire Drivers

8. Follow On-Screen Instructions

6. Turn Computer On

CONNECTION HARDWARE AND CABLE ASSEMBLIES

Communication Cables

COMMUNICATIONS CABLES		
DESCRIPTION	PART NUMBER	CONNECTION
6' RS-232 cable	400196	H1 header to female DB-9
6' USB cable	400199	H3 header to USB type A plug
TOUCH SCREEN CABLES		
DESCRIPTION	PART NUMBER	CONNECTION
12" touch screen cable	400195	Direct connect to H4 or H5

Mounting Hardware

Due to the wide variety of mounting options available for the Bergquist 5-Wire controller board, please visit the following web site to review the complete selection of available mounting hardware: http://www.rafhdwe.com/RAF_site/OnlineCatalog/EHCoverFrame.html.

On-Board Connector Specifications

Standard on-board connectors: .100" .024" square post, with mating length of .230". For complete details, please visit the following web site: <http://www.edgecards.com/index.php>.

LOCATION	MFG	PART NUMBER	DESCRIPTION
H4, H5	Sullins	PTC05DBAN	.100" 2 x 5 Position Right Dual Row Header
H1	Sullins	PTC05DBAN	.100" 2 x 5 Position Right Dual Row Header
H2, H3	Sullins	PTC02SBAN	.100" 2 Position Right Header

Mating Wire Mount Connectors (cable connections)

Any industry standard, single and/or dual row .100" socket may be used to connect to the controller board's .100" .024" square post headers. Minimum mating length is .230" socket depth.

COMMUNICATION FORMAT

USB PROTOCOL								
Byte	Bit 7	Bit 6	Bit 5	Bit 4	Bit 3	Bit 2	Bit 1	Bit 0
1	0	0	0	0	0	0	0	P
2	X7	X6	X5	X4	X3	X2	X1	X0
3	0	0	0	0	X11	X10	X9	X8
4	Y7	Y6	Y5	Y4	Y3	Y2	Y1	Y0
5	0	0	0	0	Y11	Y10	Y9	Y8
RS-232 PROTOCOL (STANDARD)								
Byte	Bit 7	Bit 6	Bit 5	Bit 4	Bit 3	Bit 2	Bit 1	Bit 0
1	1	P	X11	X10	X9	Y11	Y10	Y9
2	0	X8	X7	X6	X5	X4	X3	X2
3	0	Y8	Y7	Y6	Y5	Y4	Y3	Y2
4	0	0	0	0	X1	X0	Y1	Y0
RS-232 PROTOCOL (10-BIT)								
Byte	Bit 7	Bit 6	Bit 5	Bit 4	Bit 3	Bit 2	Bit 1	Bit 0
1	0	1	0	1	0	1	0	1
2	0	1	0	1	0	1	0	0
3	0	0	0	0	0	PU	PD	0
4	X7	X6	X5	X4	X3	X2	X1	X0
5	0	0	0	0	X11	X10	X9	X8
6	Y7	Y6	Y5	Y4	Y3	Y2	Y1	Y0
7	0	0	0	0	Y11	Y10	Y9	Y8
8	1	1	1	1	1	1	1	1
9	0	0	0	0	0	0	0	0
10	CK7	CK6	CK5	CK4	CK3	CK2	CK1	CK0
PS/2 PROTOCOL								
Byte	Bit 7	Bit 6	Bit 5	Bit 4	Bit 3	Bit 2	Bit 1	Bit 0
1	1	P	X11	X10	X9	Y11	Y10	Y9
2	0	X8	X7	X6	X5	X4	X3	X2
3	0	Y8	Y7	Y6	Y5	Y4	Y3	Y2
4	0	0	0	0	X1	X0	Y1	Y0

Where: P = 0 Pen-Up, 1 Pen-Down
 X11-X0 = 12 bit X position data
 Y11-Y0 = 12 bit Y position data
 PU = 0 no Pen-Up, 1 Pen-Up
 PD = 0 no Pen-Down, 1 Pen-Down
 CK7-CK0 = AAH + 55H + Sum of Bytes 2 through 9



www.bergquistcompany.com

**The Bergquist Company -
North American Headquarters**
18930 West 78th Street
Chanhassen, MN 55317
Phone: 800-347-4572
Fax: 952-835-4156

The Bergquist Company - Europe
Bramenberg 9a, 3755 BT Eemnes
Netherlands
Phone: 31-35-5380684
Fax: 31-35-5380295

The Bergquist Company - China
Rm. 7C, Aihe Mansion
No. 629 Ling Ling Road
Shanghai, China 200030
Ph: 86-21-6464-2206
Fax: 86-21-6464-2209

All statements, technical information and recommendations herein are based on tests we believe to be reliable, and THE FOLLOWING IS MADE IN LIEU OF ALL WARRANTIES, EXPRESSED OR IMPLIED, INCLUDING THE IMPLIED WARRANTIES OF MARKETABILITY AND FITNESS FOR PURPOSE. Sellers' and manufacturers' only obligation shall be to replace such quantity of the product proved to be defective. Before using, user shall determine the suitability of the product for its intended use, and the user assumes all risks and liability whatsoever in connection therewith. NEITHER SELLER NOR MANUFACTURER SHALL BE LIABLE EITHER IN TORT OR IN CONTRACT FOR ANY LOSS OR DAMAGE, DIRECT, INCIDENTAL OR CONSEQUENTIAL, INCLUDING LOSS OF PROFITS OR REVENUE ARISING OUT OF THE USE OR THE INABILITY TO USE A PRODUCT. No statement, purchase order or recommendations by seller or purchaser not contained herein shall have any force or effect unless in an agreement signed by the officers of the seller and manufacturer.

INS_10063_TS_CTRL_1104